



UNIVERSITY OF ROCHESTER

international theatre program

LIGHTING LAB HANDOUT

created by Gordon Rice
(with Jeff Monheit and Jon Poon)

© 2007

UR International Theatre Program

LIGHTING LAB HANDOUT

Stage lighting is used to illuminate, and to create an atmosphere or mood in any sort of theatrical production. Focused and colored beams of light are used to achieve this. The following pages will introduce you to a selection of the technology required to accomplish that.

TERMINOLOGY

Most common terms every Todd Theatre/UR International Theatre Program stage technician should know.

Items in italics means that a definition of them is available elsewhere in the document.



= useful tip or cautionary note

Barndoor – An accessory for a *Fresnel* or *Par* whose movable “flippers” are swung into the beam to control it.

BARN DOORS

An apparatus with adjustable flaps, or “barn doors” that are used to control light spill in a controlled manner. This item is available for most Altman luminaires.



Barrel (Lens Tube) – The front portion of an *ERS* that houses the lenses. Concentrates the beam into a focusable image. These come in different degrees.

Barrel Rotation Knob – Loosen this to allow to rotate the *barrel/shutter* in either direction. Found on modern *ERS* only.

Beam – The cone of light that emits from the front of any lighting *instrument*.

Beam Angle – The angular measurement in degrees of the cone of light that emits from the front of the lighting instrument.

Beam Focus Knob: Loosen this slightly to slide the barrel fore and aft in order to alter the “texture” of the light from sharp to diffused (soft). Tighten once desired effect is achieved.

Bench Focusing – The process of tuning the lighting instrument for maximum light output.

C-Clamp: Used to attach light to 1.5” pipe. (See image, below)



Channel – An electronic *patching* system in which one or more *dimmers* can be assigned to a control channel, which in turn controls the intensity level of those *dimmers*.

Circuit (in theatre lighting) – An electrical circuit terminating, on one end (closest to the stage), in a female receptacle. The other end (furthest from the stage) is connected to a *dimmer* or *patch bay*.



Cannot be used for powering Fans, Tools, Computers, etc.

Color Frame (Gel Frame) – Holds the *gel*. Will get HOT in an instrument that has already been on for a few minutes.

Color Frame Holder – Holds the *Gel Frame*. Place in slot nearest lens if more than one slot is available.

Connectors (Plug Heads) – Todd Theatre uses the 3-pin style (stage-pin) connector. Rated for 125 volts / 20 amps.



MALE 3 PIN
STAGE CONNECTOR



FEMALE 3 PIN STAGE
CONNECTOR

Dimmer – An electrical device that controls the intensity of the light source connected to it.

Drop in Iris Slot – This may be covered with a plate that you can screw off. *Iris*es or glass *gobo holders* go in here. Remember about inversion of image. (Modern *ERS* only)

ERS (Ellipsoidal Reflector Spotlight) – Nicknames: “Source 4” (new technology); “Leko” (old technology); “ERS” (abbreviation). Designed for long throws with maximum control. Manufactured with either fixed or variable focal lengths.

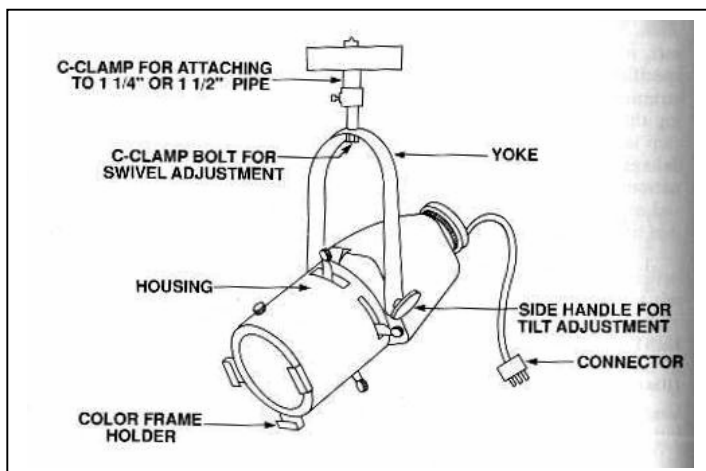

updated 1/12/2010 at 4:29:50 PM

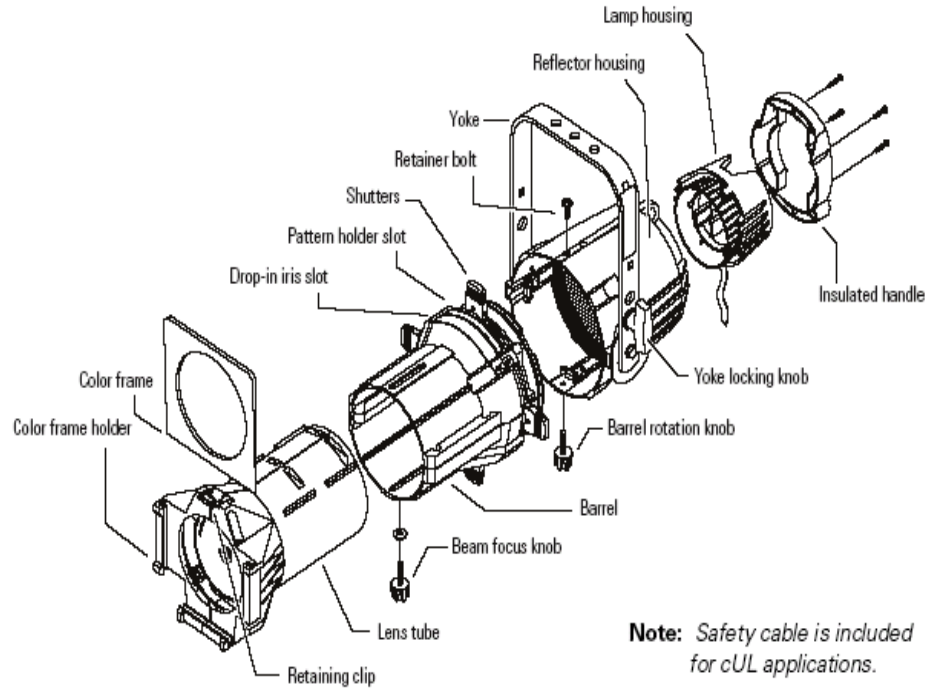

Floor Mount – An accessory which allows the lighting instrument to be placed on the floor.

Fresnel – (Fre'-nel) A spotlight that produces a soft, diffused light. Named after the lens which it utilizes. Fresnels cannot create sharp beam edges, but instead provide soft and even flood light for a general wash. The *pan* and *tilt* functions of the fresnel are similar to the *ERS*. The fresnel has limited focusing characteristics and does not have shutters. A standard fresnel:

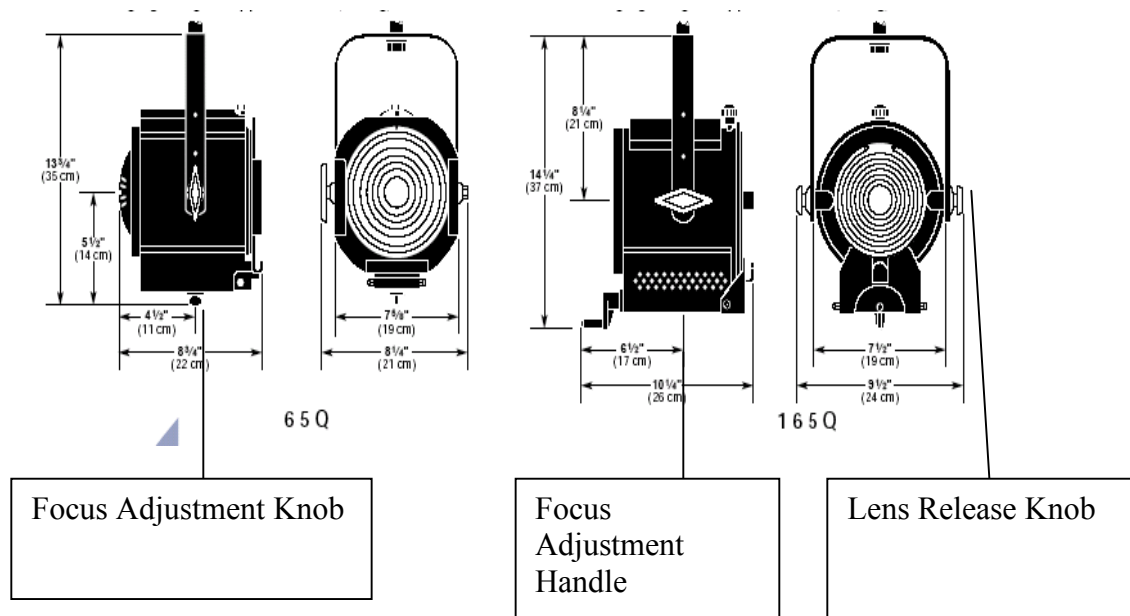

Focus Adjustment Knob – Loosen this slightly to move the *lamp housing* (sled) fore and aft. Aft is “spot”; fore is “flood”. “Flood” will be a more uniform wash while “spot” will be a have a very defined *hotspot* in the center.



Move the *lamp housing* gently. Otherwise you risk breaking the *lamp*.

Grid – A network of steel “I” beams and 1½” pipe (battens) supporting the rigging, lighting instruments, and other pieces of suspended theatre hardware/scenery.

Gel – verb: To insert color media in a color frame and place on a lighting instrument.

noun: generic term used for color media in the theatre.

Gobo – A thin metal template inserted into an *ERS* to project a shadow pattern of light. Modern gobos can now be made from glass and high temp plastics. Custom designs and color effectively transform an *ERS* into a slide-projector.

Hot Spot – The brightest part (center or near center) of a beam of light.

Instrument - Any complete stage light.

Iris – An adjustable device used in an *ERS* to alter the diameter of the circular pattern of light.

Knurled Bolt (*ERS* only) – Used for *Bench Focusing* a lighting *instrument*

Lamp – The stage term for “light bulbs” used in stage lighting *instruments*.



Never touch the bulb (i.e. the glass envelope) of the *lamp*.

Lamp Base – Touch this, not the *lamp* glass itself, when handling *lamps*.

Lamp Housing – Holds the *lamp*. Each style of a lighting *instrument* employs a different method of holding the *lamp*.



Please seek out your instructor if unsure how to change the *lamp*.

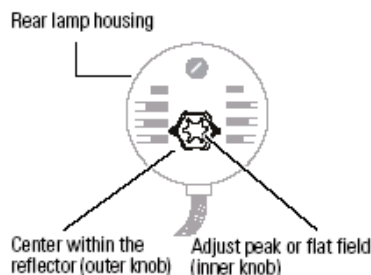

Figure 3

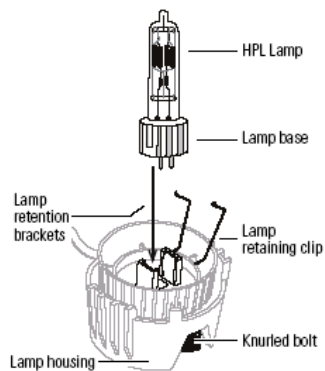

Figure 2

Lamp Housing Release Knob – Loosen completely in order to access *lamp base*.



Use caution when removing from *instrument* as the *lamp* will be connected to this.

Lens – A piece of glass that assists in controlling the light. Each lighting *instrument* uses a particular type of lens, i.e. convex, plano-convex, fresnel and more.

Lens Release Knob (*Fresnel* only) – Loosen this or pull up on it in order to release the bottom hinged *lamp housing*. It will swing down giving you access to the *lamp*.



Use caution when performing this operation in the air!

“Lock-It” – To tighten all adjustable parts of the *instrument* in order to maintain the precise position the designer intended.

Pan – Left and right focus movement. (**Tilt** – Up and down focus movement.)

Pan Screw (*commonly referred to as F-Me Nut*) – If available, it may be adjusted for left-right *pan*. If the light is shaky and moving around once it is hung, this is usually where to look.



This bolt tends to snap off, so please be careful when tightening them.

PAR (PAR can) Parabolic Aluminized Reflector – Creates a powerful punch of light with a relatively soft edge. Only instrument to have an oval shaped beam.

Patch – To connect a stage circuit to a dimmer circuit

Pattern Holder Slot – Insert a *gobo* in a *gobo holder* here.



Remember that the image will be inverted over both the x and y axis.

Pipe Bolt – Tighten until firm resistance is reached.



Do not over tighten this bolt.

Practical – An onstage working light source such as a table lamp, wall sconce or oil lamp (though actual oil would never be used).

Reflector – Mirror-like part of the lighting *instrument* designed to maximize the output of the unit.

Reflector Housing – Helps to concentrate and direct the light from the *lamp*. This gathers dust and may need to be cleaned with a soft rag and some water every few semesters.

Retainer Bolt – Prevents the barrel from falling out of the instrument.



Do not adjust.

Retaining clip (modern lighting instruments only) – Secures *gel frame* in lighting *instrument*. Move this towards the center of the *instrument*, then lift in order to put a *color frame* in. Reset once the *color frame* is in.

Safety Cable – Approximately 2' length of steel cable with a quick link on one end and a loop on the other.



Every lighting *instrument* must have a safety cable properly installed from the *instrument* to the pipe before installation is complete.

Shutter – A beam shaping device located at the aperture of an *ERS*.

Shutter Cut – The act of moving a *shutter* (found on an *ERS*) to a desired position.



Remember: the image vs. shutter is *reversed*.

Strip Light – A long narrow trough-like *instrument* with three or four *circuits* controlling the individual *lamps*. Each *circuit* is typically equipped with a separate color. Used for blending and creating color washes.

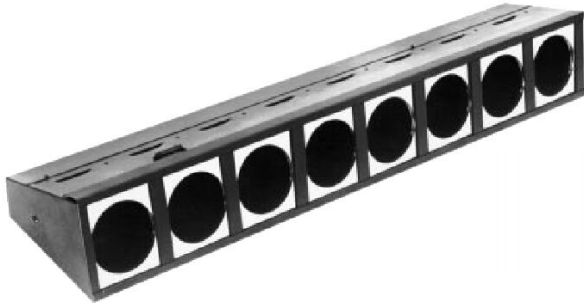

Tilt – Up and down focus movement. (**Pan** – Left and right focus movement)

Top Hat/Snoot/Funnel – Top hat looking device designed to limit beam spread and mask the light source from the audience.

SNOOTS

Snoots, or top hats, are devices used to reduce light spill. This accessory is available for most Altman lighting fixtures.



Yoke – This is how the light mounts. It may be done with a *C-clamp* or with a *floor mount*.

Yoke Bolt and Lock Washer – Attaches *yoke* to *C-clamp*. Can be loosened slightly to achieve left-right *pan*.



Do not over tighten, follow above rule for tightening. Typically a $\frac{1}{4}$ turn past firm resistance is as much as you will ever need for tightening bolts.

Yoke Locking Knob – Loosen this so that the light can *tilt* up and down; tighten it to lock the position of the light.

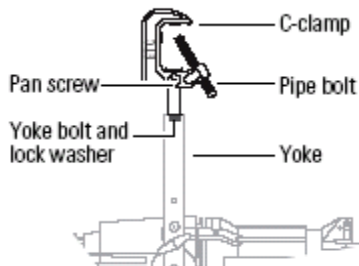

Mounting section of a lighting instrument

SAFETY TIPS

1. Ladders are safe as long as you position the ladder on a stable surface both bottom and top.
2. Always better to come down and move a ladder rather than r-e-a-c-h out to complete your task.
3. Always have a buddy supporting your ladder once you have ascended it.
4. Lights get hot when they are on. A good pair of work gloves will save your fingertips when you are focusing instruments.
5. You will need to have a crescent wrench (usually an 8" adjustable crescent wrench). It should be the only tool you will need to hang and focus lights.
6. Keep in mind what is happening below you when you are on a ladder. A wrench dropped from 15 feet can cause serious injury to your crew below (and it really pisses them off).
7. Don't attempt to hang a light until you feel steady on your ladder, we have ropes on our ladders so that you can use both hands to find yourself a comfortable position then haul the light up.
8. Don't work alone, always have a buddy.
9. If you do drop something from above *immediately* yell "HEADS!!". This is a universal warning in the theatre industry, alerting the crew/actors below to get out of the way or to quickly cover up.

GENERAL TIPS FOR HANGING LIGHTS:

1. Do not overtighten bolts.
2. Do not overtighten bolts.
3. Do not overtighten bolts.
4. Do not forget rules 1-3.
5. **Every lighting instrument must have a safety cable properly installed.**
6. Run cable to a light, not to the end of the instrument cable. That slack is there so that the light can be focused, not to make cabling easier. Male ends of cable always point towards the source of power. Female ends of the cable always point towards the light. There will be a small coil of cable at the end of each instrument with a male end (tail). Do not stretch this out along the grid, run a female cable end from the circuit to the light. There must be slack in the instruments tail so that the light can be turned in its full range of motion when focus time comes.
7. Never coil cable around the pipes. Use tie-line to dress cable.
8. Try and hang the light so that the yoke makes a 90° angle with the pipe. This will ease focus.
9. Always pull shutters once the light is hung.

10. Do not let go of an *instrument* until you are sure that the *C-clamp* is attached securely, or until the *safety cable* is attached to both the *pipe* and the *instrument*.
11. If the cable does not stay plugged in once you first try it, attempt to split/separate the pins slightly with a knife or pin-splitter before you tape a connection (seek advice first).
12. If you do tape a connection, leave a pull tab to ease strike.
13. Use only black tie-line to dress your cables. Always tie with a single bow (just like your shoes).
14. Don't fall.
15. If you don't know, PLEASE ASK. We are around for a reason.